

# INSTALLATION AND OPERATING INSTRUCTIONS

## Diagonal In-Line Duct Fan HIDE

**APPLICATION:**  
DVP HIDE fans can be used in industrial and residential premises (workshops, halls, warehouses, garages, bathrooms).

**CONSTRUCTION:**  
The DVP HIDE fan features:

- A single-phase asynchronous induction motor designed for continuous operation,
- A radial turbine and housing made of polymeric materials.

**CONTROL:**  
The DVP HIDE fan does not require frequent checks. The fan is designed for continuous operation and periodic checks can be carried out depending on the operating conditions of the fan.

**INSTALLATION:**  
The DVP HIDE fan is installed on a wall, ceiling, or a frame prepared for the installation of circular ducting. Connection to the electrical installation must be performed by an electrician with professional qualifications!

After unpacking the fan, check:

- The condition of the fan housing (dents, deformation),
- The impeller should not rub against the casing.

Data on the technical label must correspond to the parameters of the electrical installation at the fan connection point. It is recommended to check the condition of the product for possible damage during transport.

**!!! ATTENTION !!!**  
Before starting the installation, turn off the power supply to the electrical system! Inspect and check the installed fan. If no damage is found, you can proceed with the installation:

- prepare the electrical connection
- fix the fan to the ventilation ducting
- place the ducting on both sides of the flanges molded into the housing
- secure the ducting using screws and a screwdriver
- connection to the electrical installation must be performed by an electrician with professional qualifications!

**MAINTENANCE:**  
To remove dirt from the fan:

- disconnect the fan from the mains
- disassemble the fan - in case of severe contamination, disassemble the turbine using a screwdriver or wrench
- thoroughly wipe all components with a damp cloth and a little detergent, being careful not to get the motor wet
- after wiping all components dry, reassemble the fan
- mount the fan back to its original location

**MOTOR MAINTENANCE:**  
The motor should be checked regularly depending on the conditions, at least every 2 years. Inspection and control should be carried out by a person with the appropriate qualifications. The following should be checked:

- insulation and winding resistance,
- bearing condition.

**ELECTRICAL CONNECTION:**  
Make sure that the voltage (V) and frequency (Hz) of the power source at the installation site correspond to the values indicated on the rating plate. After installation, it must be possible to disconnect the device from the power supply. This is done by turning off the local protective element (circuit breaker, residual current device) of the fixed electrical installation to which the fan is connected and which, by its design, complies with the electrotechnical standards in force at the installation site with regard to the influence of external factors. The device must be permanently connected to the electrical installation on the fan side. (A2- or 3-core cable with a minimum cross-section of 1mm<sup>2</sup> and a maximum of 1,5mm<sup>2</sup> via a terminal block, which is part of the fan and is located under a cover that is screwed to the fan.  
For electrical connection, proceed according to the wiring diagram (see Fig. 3A, 3B, 3C). Wiring 3A and 3B allows speed selection Low/Medium/High and is selected using a suitable switch that has 3 switching positions. If we choose a connection without a switch, we can choose only Low or Medium or High speed independently, depending on which terminals we apply voltage to. The fan must have voltage applied at one moment only on two terminals, otherwise it will be damaged. Wiring 3B is the standard wiring of the fan, we connect conductors L and N to the terminal block – it does not allow speed selection.

Description of incoming conductor connections according to diagram 3A, 3B on the connecting terminal block:

- 1 wire N
- 2 wire L - high speed
- 3 wire L - medium speed
- 4 wire L - low speed

**!!! ATTENTION !!!**  
The color coding of the wires - internal connection of the electric motor to the connecting terminal block does not correspond to the color coding used for electrical standards (electrical installations). This is an internal connection made by the manufacturer - part of the product.  
The device does not have a terminal for connecting a protective conductor. It is a class II electrical protection object. Pull the power cable through the insulated holder (O). Position the power cable to prevent the entry of liquids or vapors. The power cable must meet the method of installation when passing through a grommet declared IP protection specified on the fan label. Work must be performed by an electrician with professional qualifications! The device has one, two, or three motor speeds (depending on the model).

Available versions:  
STANDARD, no adjustment is required

**SETTINGS AND OPERATION:**  
Perform the settings according to the installed model. The exhaust fan turns on when activated by a switch. Before putting the fan into operation, make sure that all connections to the electrical supply network have been made correctly according to the manual and that the cables are connected in accordance with the wiring diagrams according to the type and model of the installed fan. Put the cover back to the correct position and make sure it cannot be removed without using a tool. Make sure the blades rotate freely.

**!!! ATTENTION !!!**  
Connection to the electrical network must be carried out by an electrician with professional qualifications and the necessary license! Before starting maintenance, adjustment, or cleaning, always disconnect or turn off the fan from the electrical network! The electrical installation must include a switch in which the distance between the contacts of all poles is not less than 3 mm. Ventilation must not be routed into a common flue with another open-flame appliance. Fans should not be used in rooms with high humidity and in areas with a risk of explosion. During operation, it is forbidden to handle the fan without prior disconnection from the network. The fan must always be installed in accordance with the manual.

**WARRANTY:**  
The HIDE duct fan comes with a 2-year warranty from the date of purchase. The warranty is valid only with a proof of purchase and a properly completed claim report. The warranty does not cover defects caused by external mechanical forces, contamination, improper modifications, chemical factors, or unprofessional installation.  
Maximum continuous operating time: 5000 hours

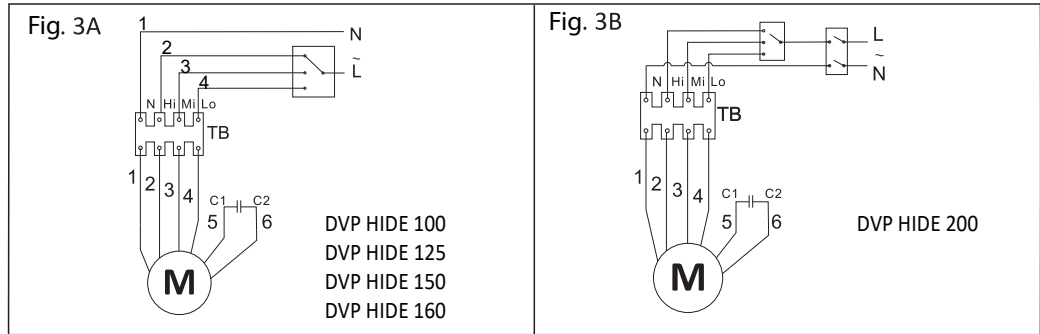
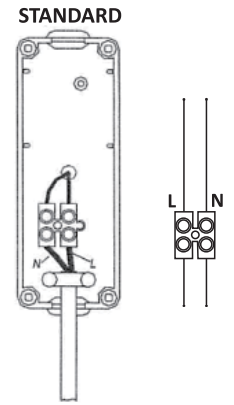
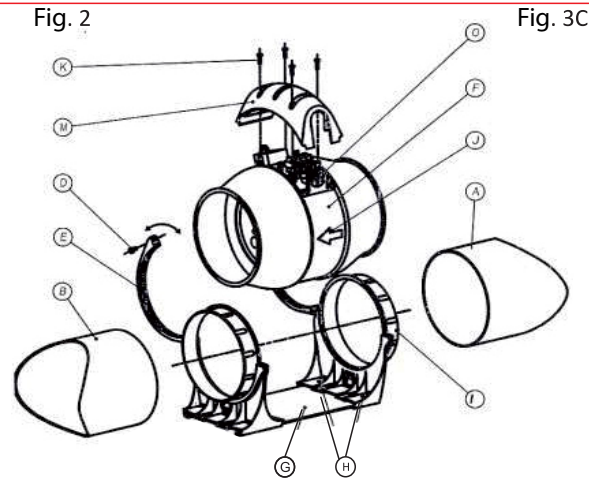

1	N	NEUTRAL CONDUCTOR
2	Hi	PHASE CONDUCTOR FOR HIGH SPEED
3	Mi	PHASE CONDUCTOR FOR MEDIUM SPEED
4	Lo	PHASE CONDUCTOR FOR LOW SPEED
5	C1	MANUFACTURER'S INTERNAL CONNECTION - DO NOT TAMPER
6	C2	MANUFACTURER'S INTERNAL CONNECTION - DO NOT TAMPER

DVP HIDE	100	125	150	160	200
Proud vzduchu/ Air flow/ Расход воздуха/ Luftstrom m <sup>3</sup> /h	120/138/198	180/200/280	288/330/432	288/330/432	660/750/970
Akustický tlak/ Acoustic pressure/ звуковое давление/ Schalldruck dB(A)	41/46/56	41/46/56	54/55/63	54/56/63	61/63/68
El. napájení/ Supply voltage/ частота напряжения/ Versorgungsspannung ~50 Hz	220-240 V	220-240 V	220-240 V	220-240 V	220-240 V
Napájení/ Power/ мощность двигателя/ Leistung W	22/24/33	24/26/36	40/45/55	40/45/55	110/115/135
Tlak/ Pressure/ давление/ Druk Pa	90/110/140	80/100/140	100/150/220	100/150/220	240/280/290
Spotřeba energie/ Power consumption/ потребляемая мощность/Energieverbrauch A	0,09/0,09/0,11	0,09/0,10/0,12	0,17/0,18/0,18	0,17/0,18/0,18	0,44/0,45/0,45
Max. pracovní teplota/ Max. working temperature/ Мак. рабочая температура/ Max. Arbeitstemperatur °C	35	35	35	35	40
Váha/Weight/ вес/ Gewicht Kg	2	2,1	2,9	2,9	4,9
Stupeň ochrany/ Degree of protection/ Степень защиты/ Stärke des Schutzes	IP X2	IP X2	IP X2	IP X2	IP X2

